

Što na kvantne oscilacije mogu otkriti o svojstvima materijala

Predavanje u sklopu kolegija: Eksperimentalne tehnike u fizici

Plan predavanja:

- ❑ Eksperimentalni rezultati i saznanja koja će nas motivirati da razumijemo novu eksperimentalnu tehniku
- ❑ Kako možemo mjeriti kvantne oscilacije u magnetizaciji

Supravodljivi kvantni interferometar

Superconducting QUantum Interference Device

SQUID-magnetometra

□ Definicija magnetizacije

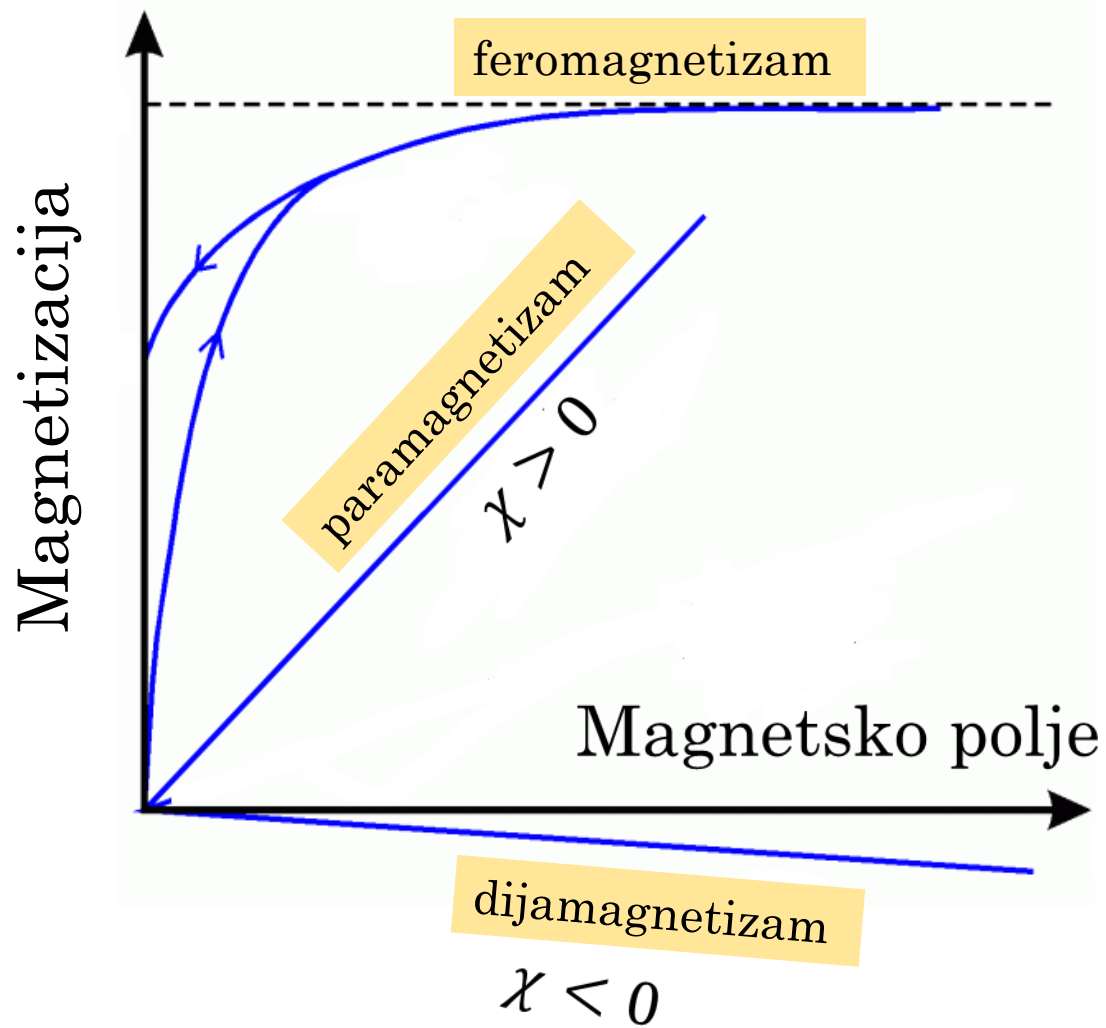

Magnetizacija: odgovor materijala na vanjsko magnetsko polje

$$\vec{M} = \chi \vec{H}$$

↑
Tensor susceptibilnosti

Odgovor kristala $\text{Pb}_{0.83}\text{Sn}_{0.17}\text{Se}$ na vanjsko magnetsko polje daje oscilacije

Magnetizacija

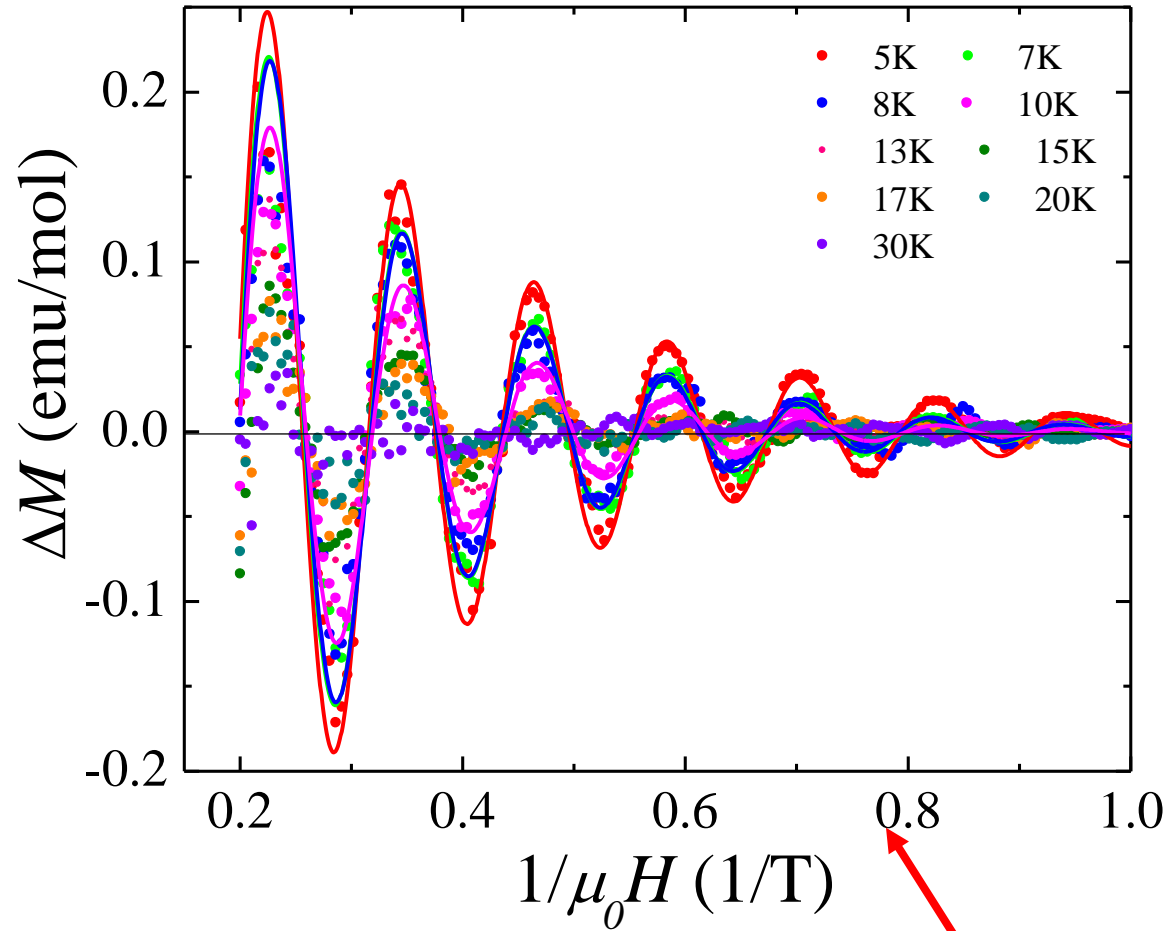

Izgled kristala

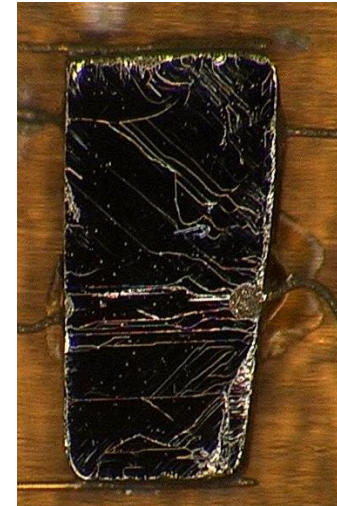

Primijetite da je polje invertirano

- ❑ Oscilacije magnetizacije u vanjskom polju nazivaju se: de Haas-van Alphen oscilacije (dHvA)
- ❑ Pozadina dHvA oscilacija leži u Landu kvantizaciji

Energija slobodnog elektrona $E(\vec{p}) = \frac{\vec{p}^2}{2m_e} \leq E_F$

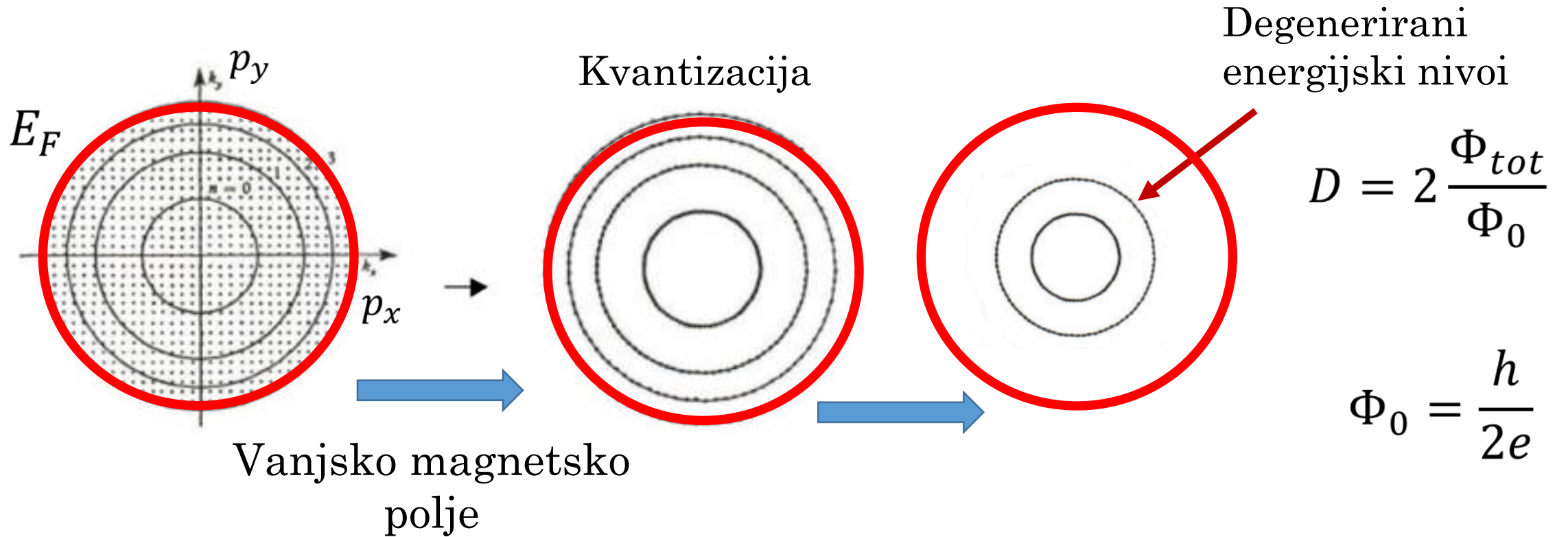

□ Oscilacije magnetizacije kriju puno informacija o materijalu

- koncentraciju elektrona
- oblik Fermijve plohe
- efektivna masa elektrona
- vrijeme između sudara elektrona
- spinsku informaciju

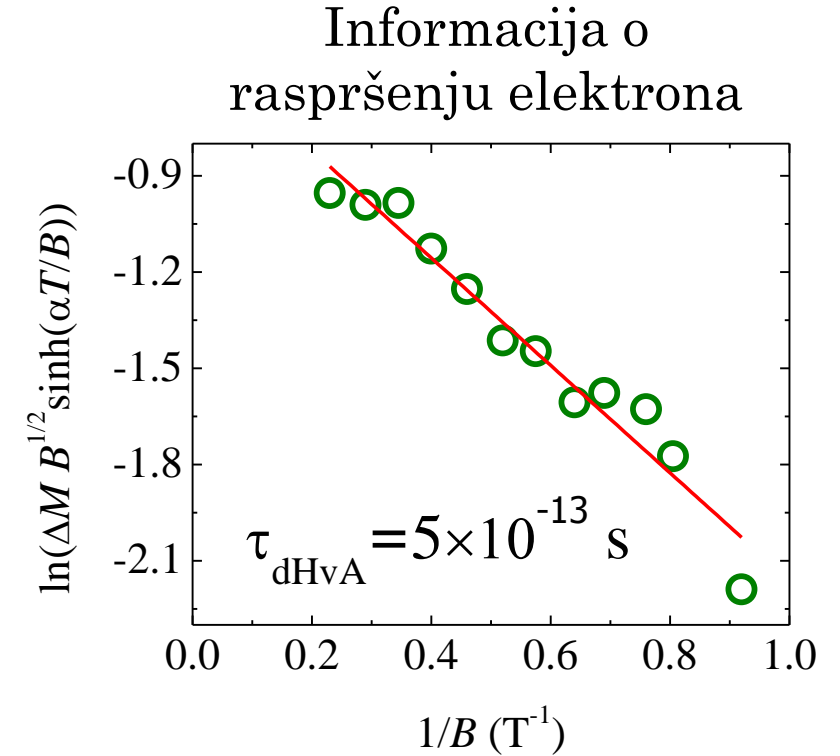
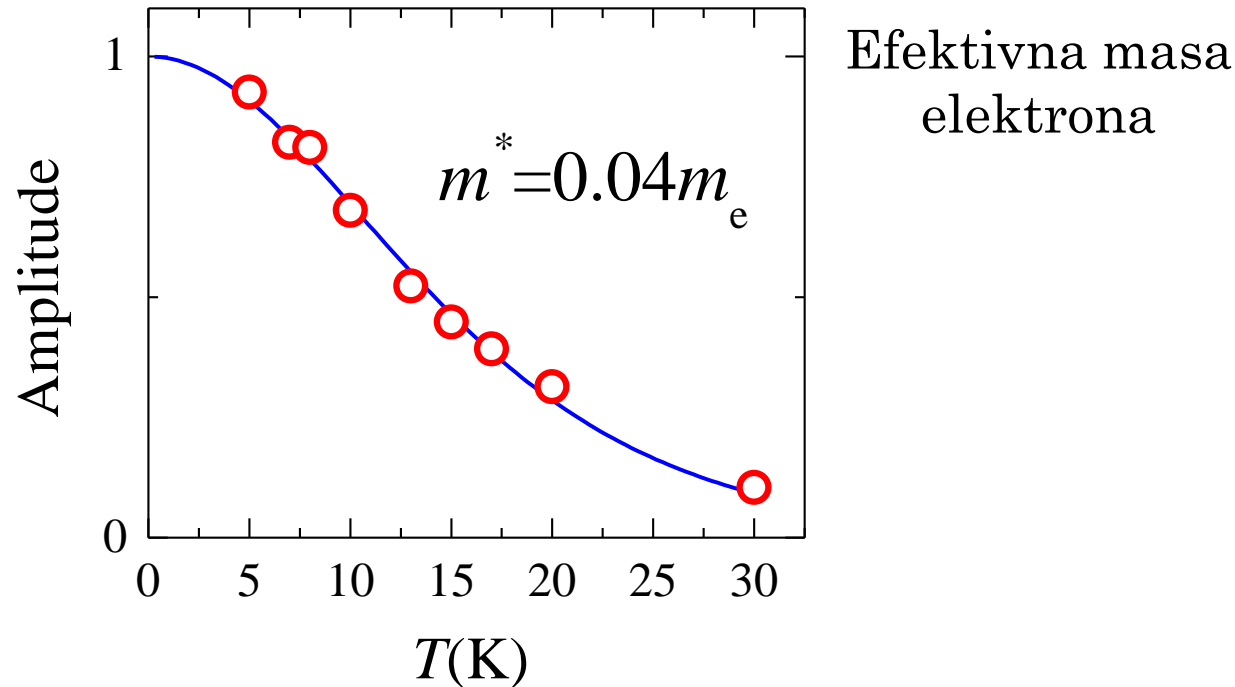

dHvA oscilacije su općenito vrlo slabi efekt te trebamo sofisticiranu metodu da ih detektiramo

SQUID magnetometer

- ❑ Uređaj za mjerenje statičke (DC) magnetizacije
- ❑ Osjetljivost \sim fT !

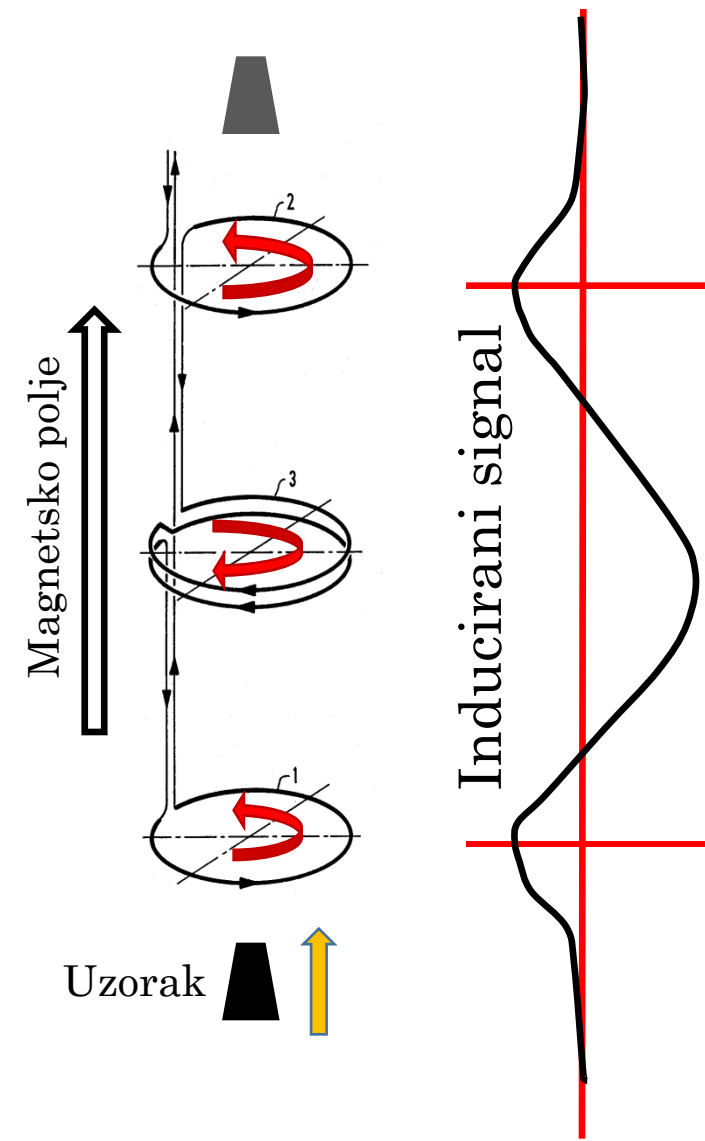
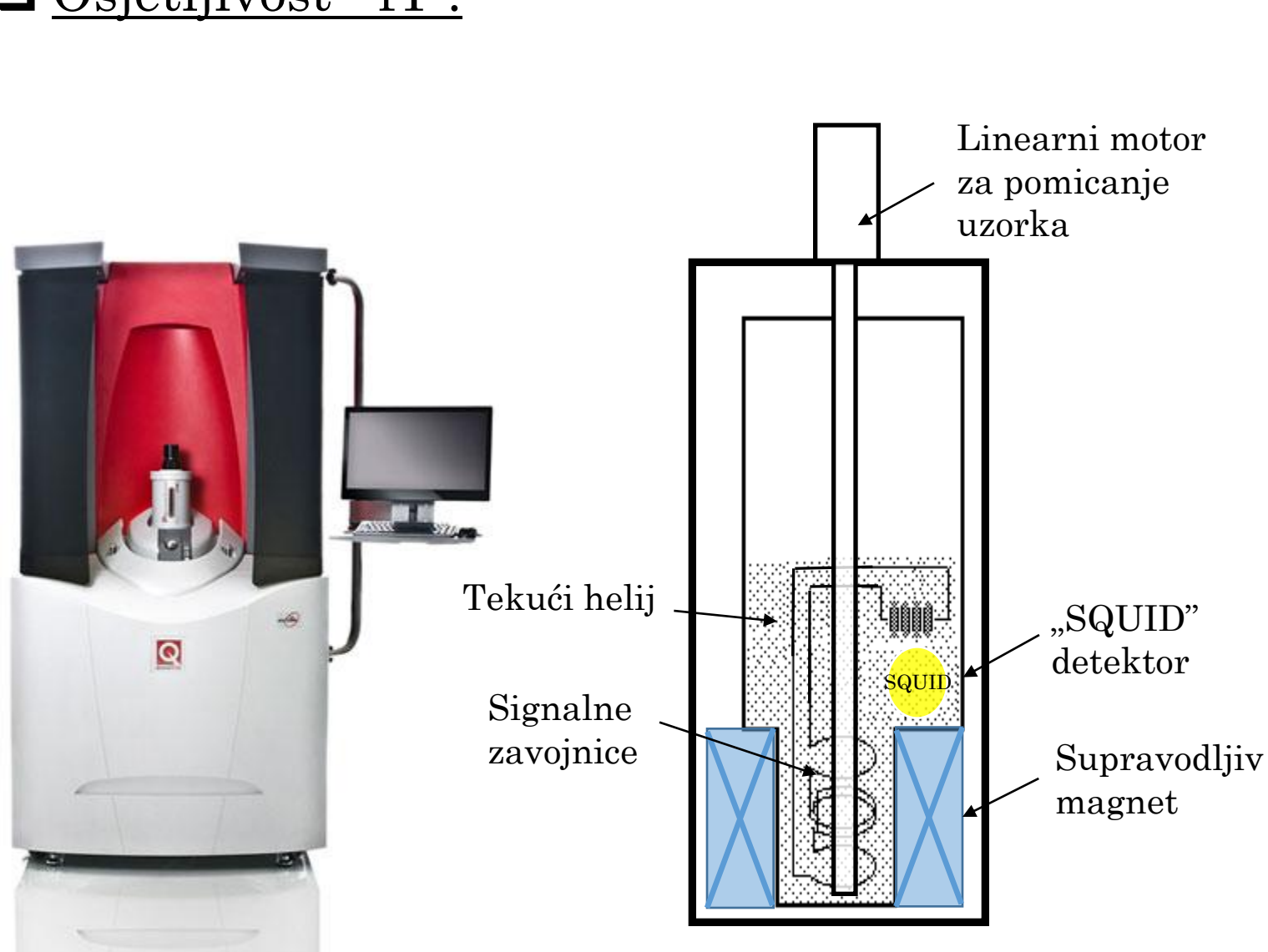

SQUID magnetometer

- Uređaj za mjerenje statičke (DC) magnetizacije

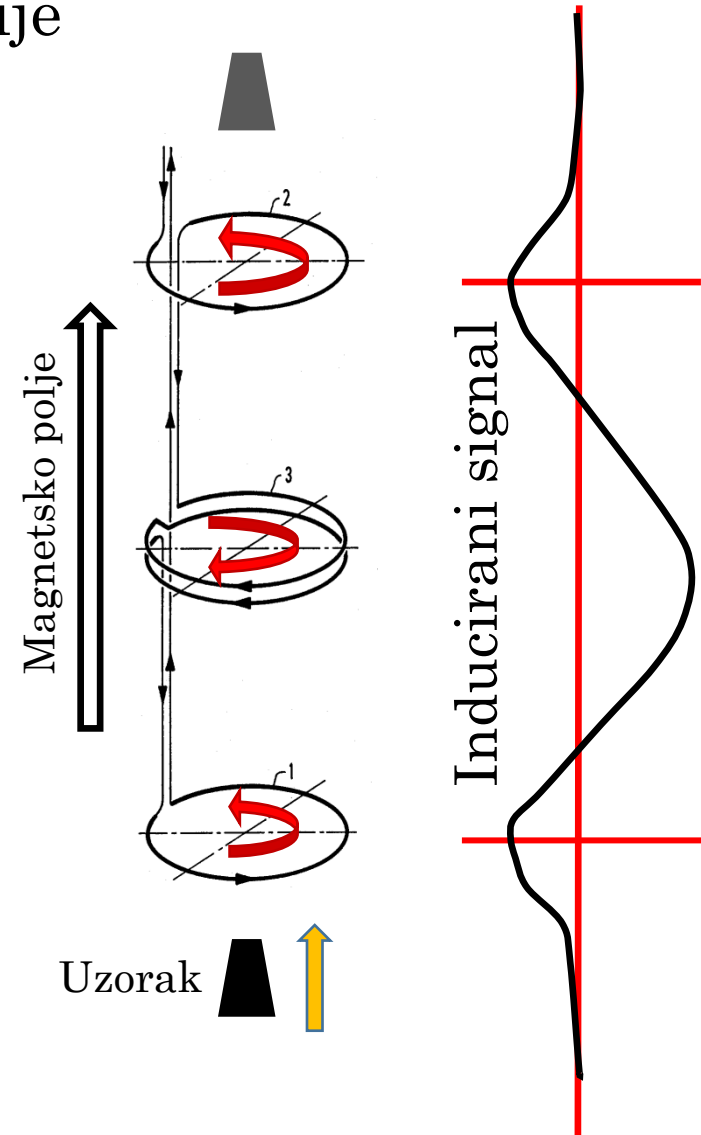

SQUID detektor

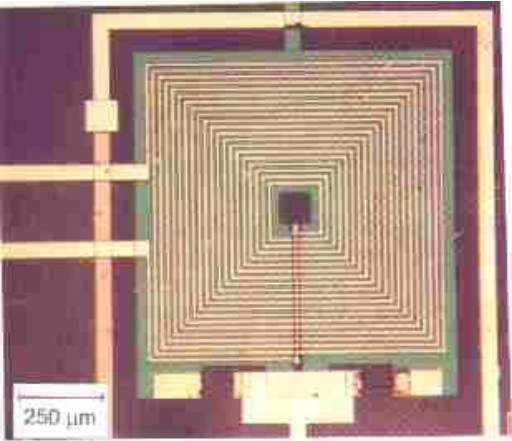
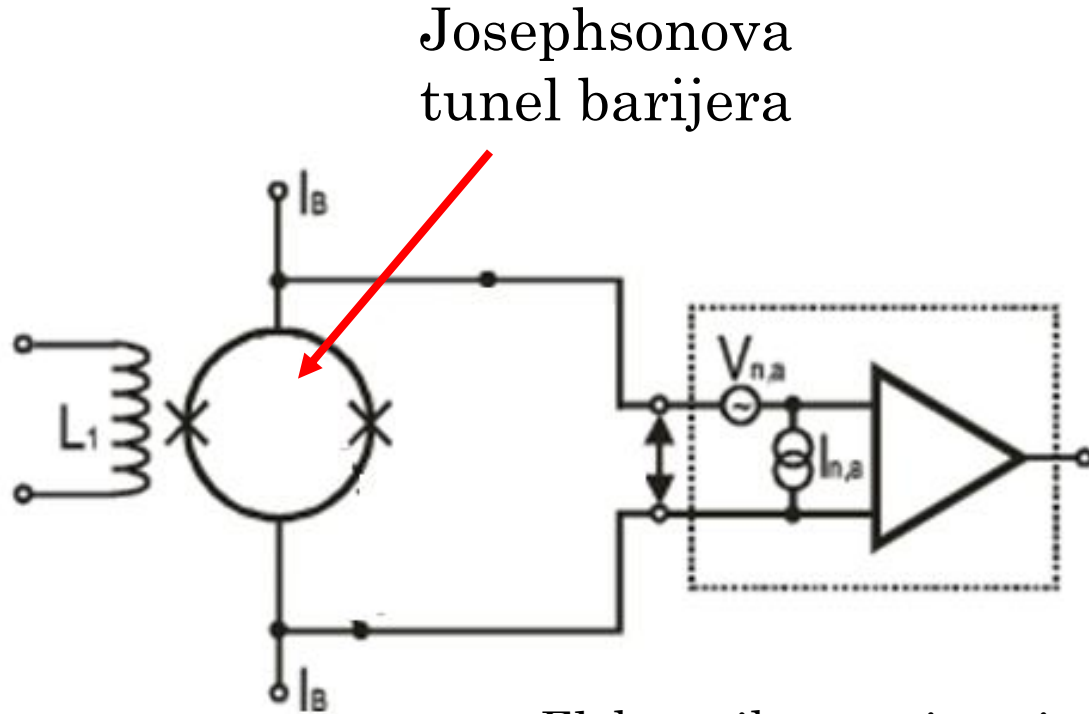
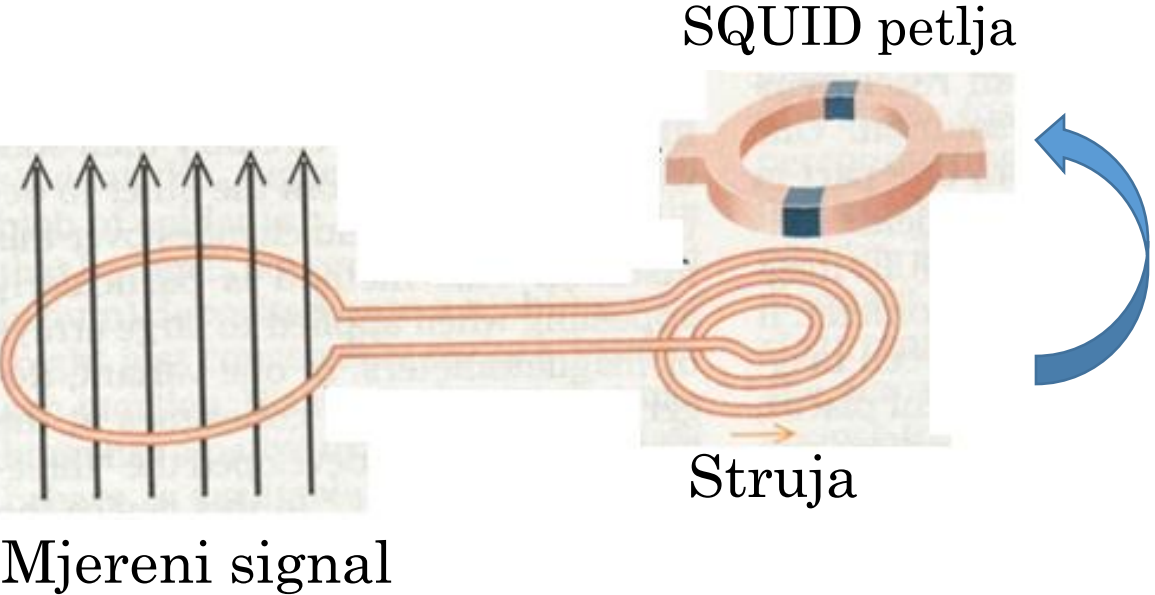
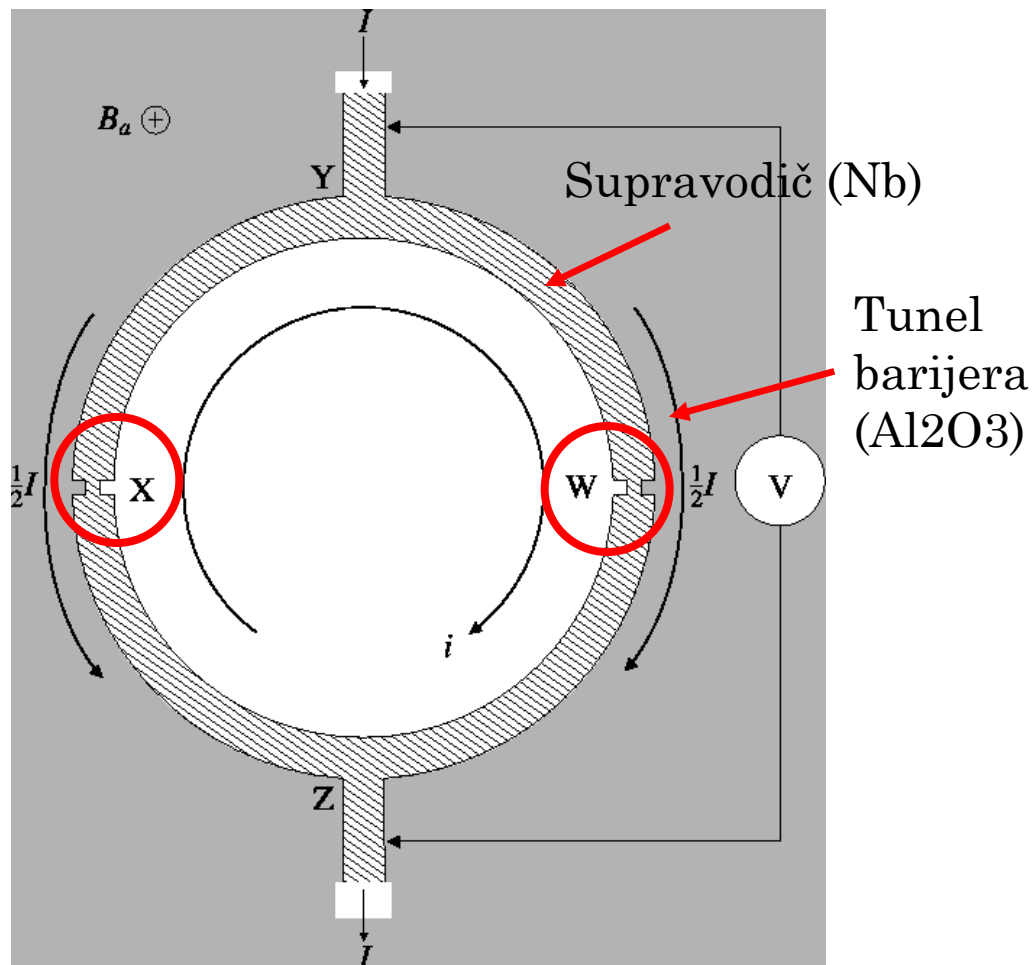

Figure 5: Photograph of a typical DC SQUID sensor based on the Ketchen-Laycox design.

Stvarni izgled SQUID detektora

Elektronika za mjerenje napona

SQUID petlja



- Tunel barijera snižava kritičnu supravodljivu struju j_c

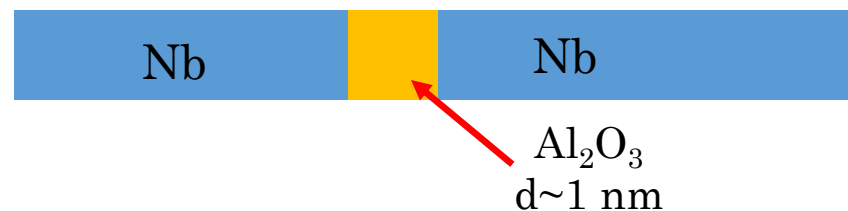

- (Ukupan) Magnetski tok kroz petlju je kvantiziran

$$\Phi = n\Phi_0$$

- Kvant magnetskog toka

$$\Phi_0 = \frac{h}{2e}$$

Inducirana struja

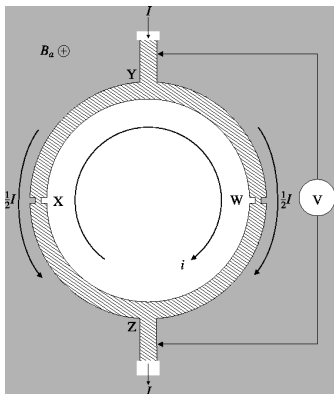
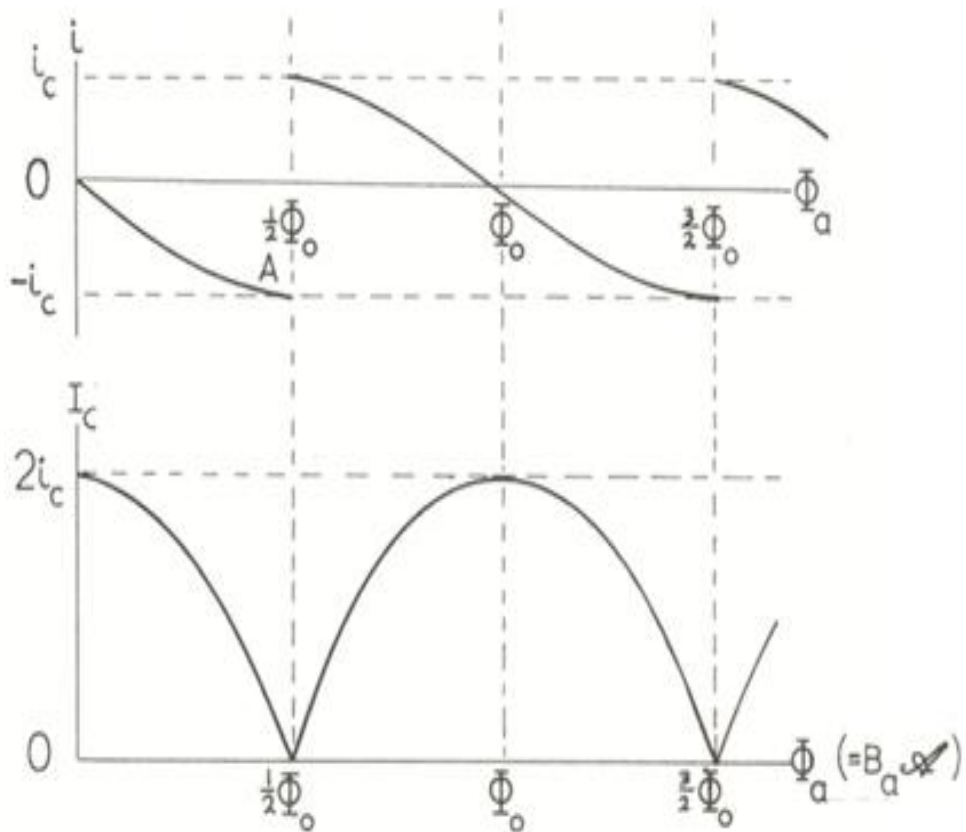

- Vanjsko magnetsko polje inducira supravodljive struje
- Supravodljiva struja je vođena zahtjevom

$$\Phi = n\Phi_0$$

PITANJA:

- ❖ Zašto $I_c = 2i_c$?
- ❖ Kako bi izgledala donja slika kad se i_c poveća?
- ❖ Koliki najmanji tok možemo izmjeriti?

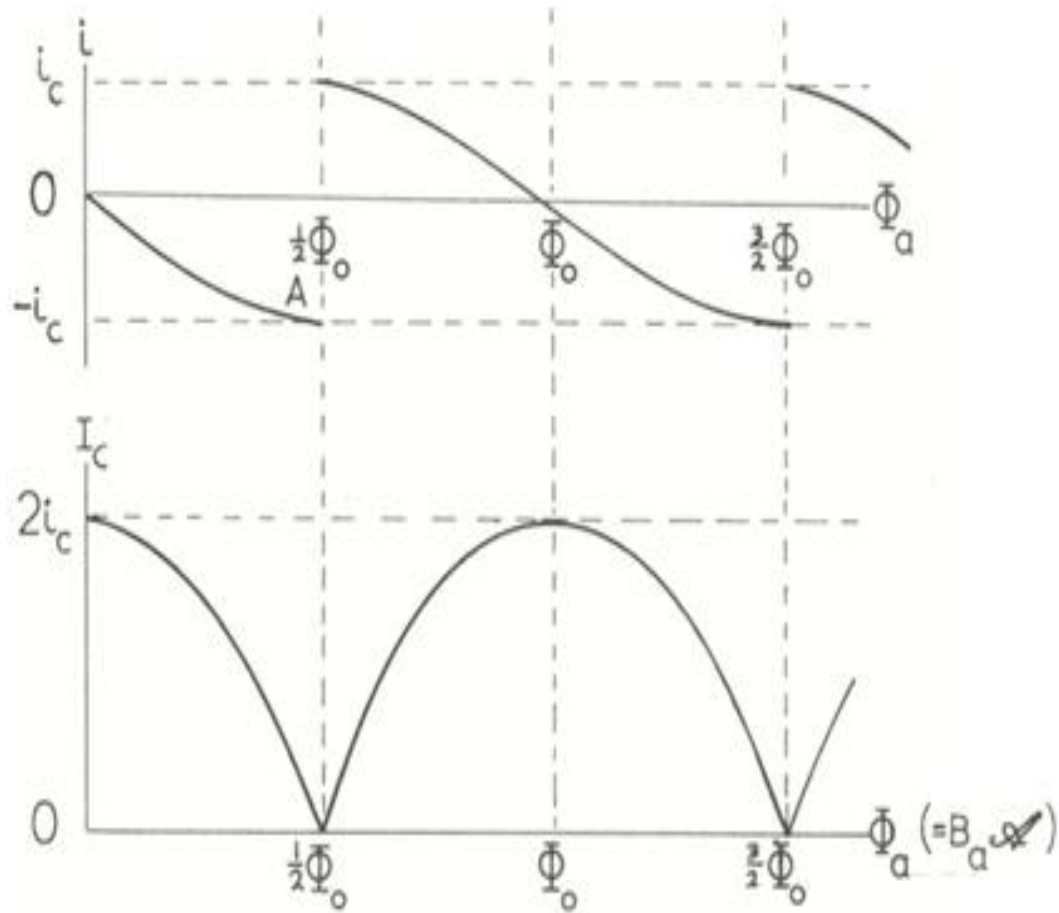

□ Interferencijski uzorak

$$I_c = 2i_c \cos\left(\frac{\Phi_B}{\Phi_0}\right)$$

- Da bi odredili apsolutni Φ_B a time i apsolutni magnetski moment mjerelog uzorka moramo krenuti od $\Phi_B \approx 0$

$$\Phi_B \Rightarrow M$$

Kako se mjeri signal?

- ❑ Mjerenje kritične struje nije praktična metoda
- ❑ Želimo mjeriti napon

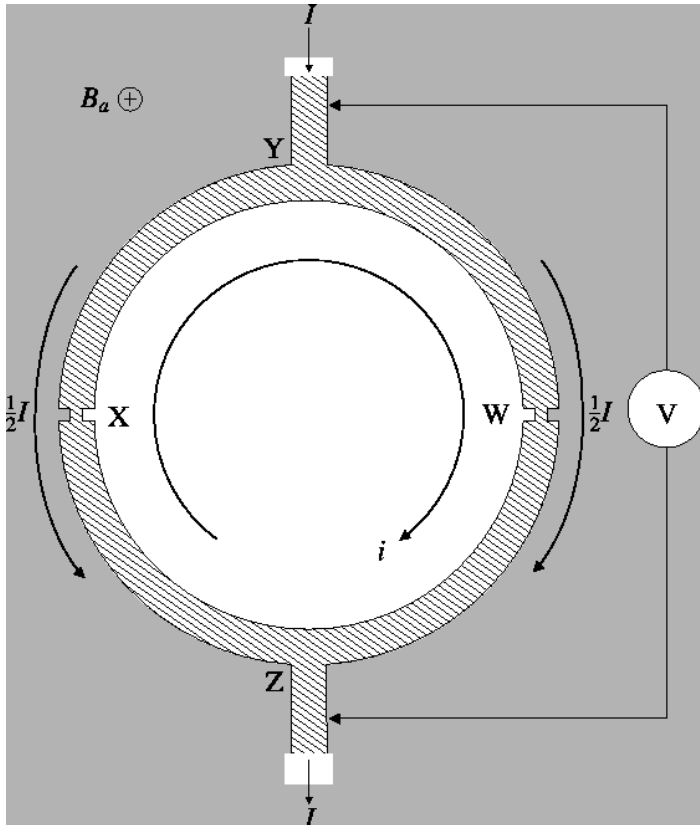

Uvjet da možemo
mjeriti napon

$$I > I_c$$

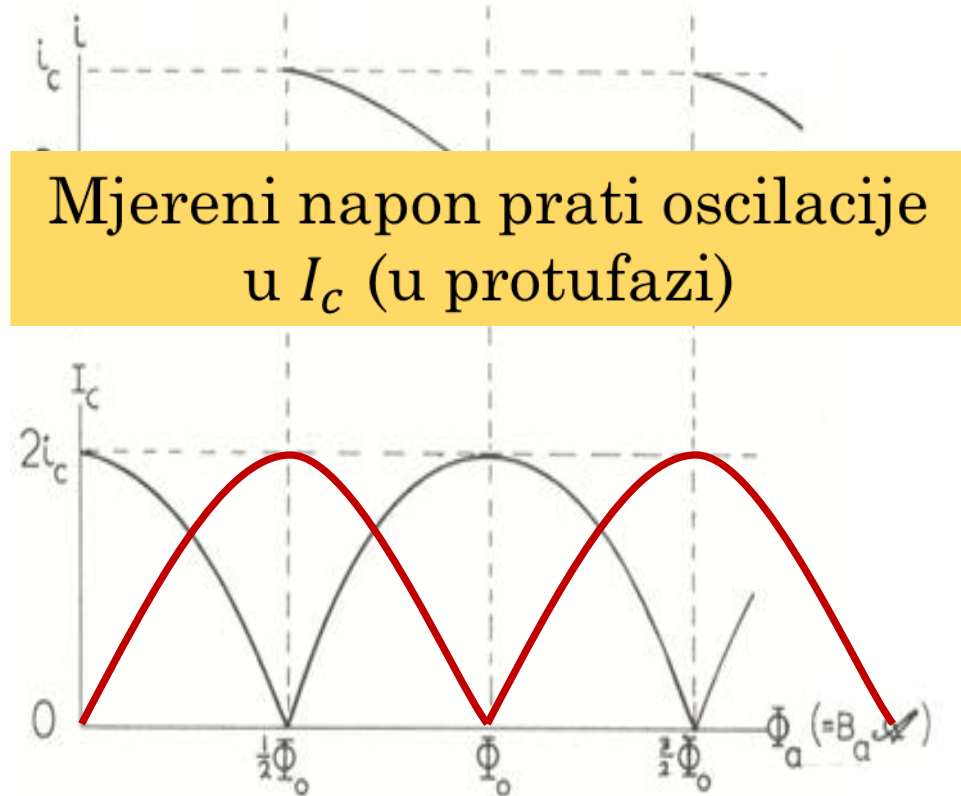

Gdje se još koristi SQUID magnetometar



Snimanje mozga

Geofizika i geologija

Figure 1 from T.Hate et al. 2013 Supercond. Sci. Technol. 26 115003

